

PMC450

Serial Controller PMC (RS422)

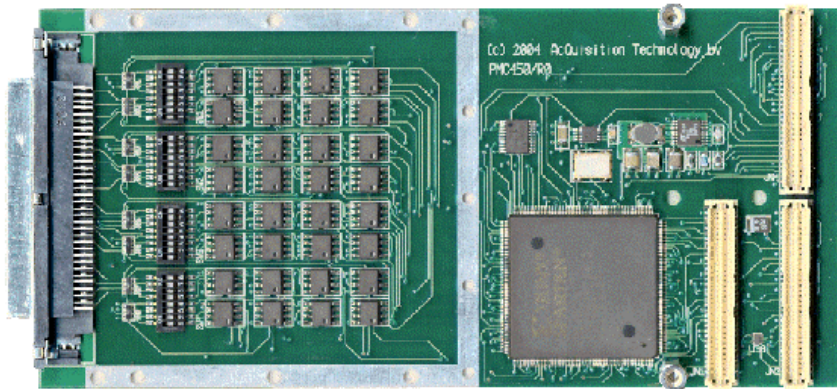

The PMC450 is a FPGA-based 8 channel RS422 serial PMC card with front and rear I/O.

The standard configuration consists of a PCI-core and eight 16C550-uart compatible cores. With the 32 onboard RS422 transceivers 8 serial RS422 channels (Rx, Tx, RTS and CTS) are created. The PMC450 features a 68-pin high dense connector at the front for the connection of all the RS422 channels. A PIM (PMC I/O Interface) for rear I/O is optional. Usage in ruggedised systems with conductive cooling is also possible.

Because of the fully FPGA-based design, custom protocol interfaces for RS422 and RS485 are available on request. Examples of custom specific protocol interfaces are e.g. Serial I/O, Encoder Interfaces, Stepper Motor Controllers and more.

Features:

- > Single PMC slot (IEEE 1386.1-2001) with front I/O and rear I/O
- > Optional PIM450 (VITA 36) for rear I/O connections
- > Xilinx FPGA softcore PCI interface
- > 16C550 compatible host interface
- > FIFO Depth 16 bytes
- > Communication parameters 115Kb
- > PCI interface: PCI2.1 compliant, 33MHz, 32-bit interface, 3.3V and 5V signalling supported, 5V supply
- > 8 serial RS422 channels with Rx, Tx, RTS and CTS at 68-pin front or 64-pin rear connector
- > Dipswitch selectable line termination
- > Operating temperature 0..60°C and -40..+85°C

PCI Compliancy

- * PCI 2.1 compliant
- * PMC: IEEE 1386.1-2001 compliant
- * 33MHz, 32-bit interface
- * 3.3V or 5.0V PCI signalling
- * 5V supply voltage
- * PIM: VITA 36 compliant

Host Interface

- * Xilinx Spartan FPGA-based
- * Softcore PCI/PMC-interface
- * 16C550 compatible programming interface
- * Custom host interfaces or line protocols available on request

Line Interfacing

- * 32x RS422 transceivers in a default configuration of 8 transceivers with Rx, Tx, RTS and CTS
- * Dipswitch selectable line termination
- * High dense 68-pin front connector

Ordering Information

- * **PMC450/T01** PMC Serial Controller Card with front and rear I/O, 0..60°C
- * **PMC450/T02** PMC Serial Controller Card with front and rear I/O, -40..+85°C
- * **PIMSCSI68/T01** Generic PIM which converts I/O signals to 68-pin SCSI

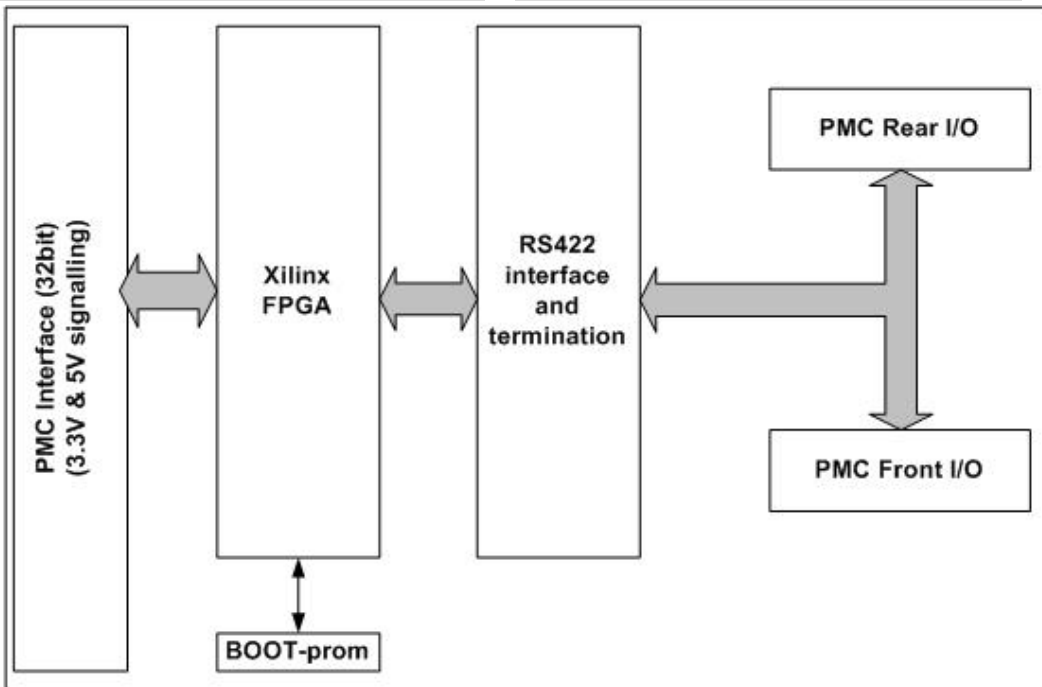

AcQ International BV
 Alanenweg 6
 5342 PV OSS
 The Netherlands

Phone +31 (0)412 64 19 22
 Internet www.acq.nl
 E-mail info@acq.nl