

PCI392

16 Channel ADC for PCI

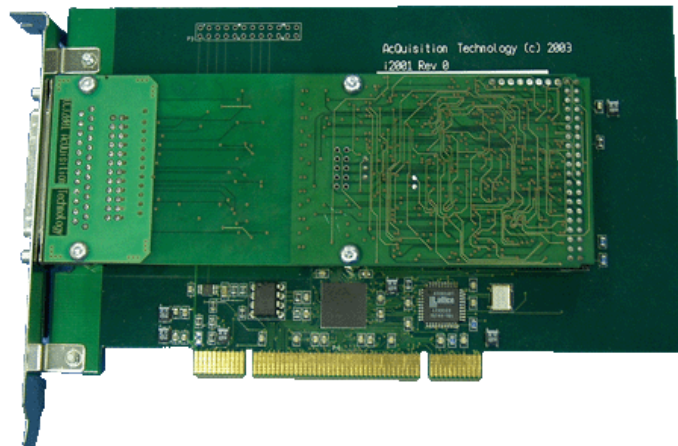

The PCI392 16-Channel Common-Mode Input ADC for PCI is very well suited to be used in applications in which autonomous signal conversion is an issue, as well as in standard mid-range applications. Enabled channels are scanned at maximum rate and conversion results are stored in shared memory. A local DSP performs all functionality like calibration. User-specific functions can be added for customized operation.

Features:

- > 100kSPS ADC with 16-bit or 12-bit resolution
- > Channels can be enabled/disabled individually
- > No potentiometers
- > 16 single ended input channels
- > On-board filtering with 1kHz cut-off frequency
- > Analog front-end is optically isolated
- > On-board DC/DC converter for isolated power supply
- > Data acquisition handled by TMS320C203 DSP, transparent for user
- > Calibration data stored in EEPROM
- > Measurement values continuously updated in dual-ported SRAM
- > Update rate up to 50kHz
- > PCI9050 Controller by PLX (PCI 2.1 compliant)

PCI Interface

* The PCI392 has a PCI Specification 2.2 compliant target interface and uses a PCI9030 PCI Bus Target Interface Chip by PLX Technology Inc.

Input Characteristics

- * 16 common-mode inputs
- * Optical isolation
- * Uni-polar input range: 0V .. +5V / 0V .. +10V
- * Bi-polar input range: -5V .. +5V / -10V .. +10V
- * Input ranges are software programmable
- * 2nd order input filter with 1kHz cut-off frequency

Conversion Characteristics

- * 12-bit or 16-bit conversion accuracy (see ordering information)
- * Typical acquisition time of 10 microseconds per channel
- * All enabled channels are converted continuously
- * Conversion data can be read from shared memory by host
- * Local DSP (TMS320C203) performs acquisitions sequences.
- * User-specific features (e.g. running average) can be implemented on request

Ordering Information

- * **PCI392/T03** 16-channel analog input, common mode, 12-bit resolution, without DCDC
- * **PCI392/T01** 16-channel analog input, common mode, 12-bit resolution, with DCDC
- * **PCI392/T04** 16-channel analog input, common mode, 16-bit resolution, without DCDC
- * **PCI392/T02** 16-channel analog input, common mode, 16-bit resolution, with DCDC
- * **PCI392/SW** APIS based software
- * **PCI392/MAN** manual on paper

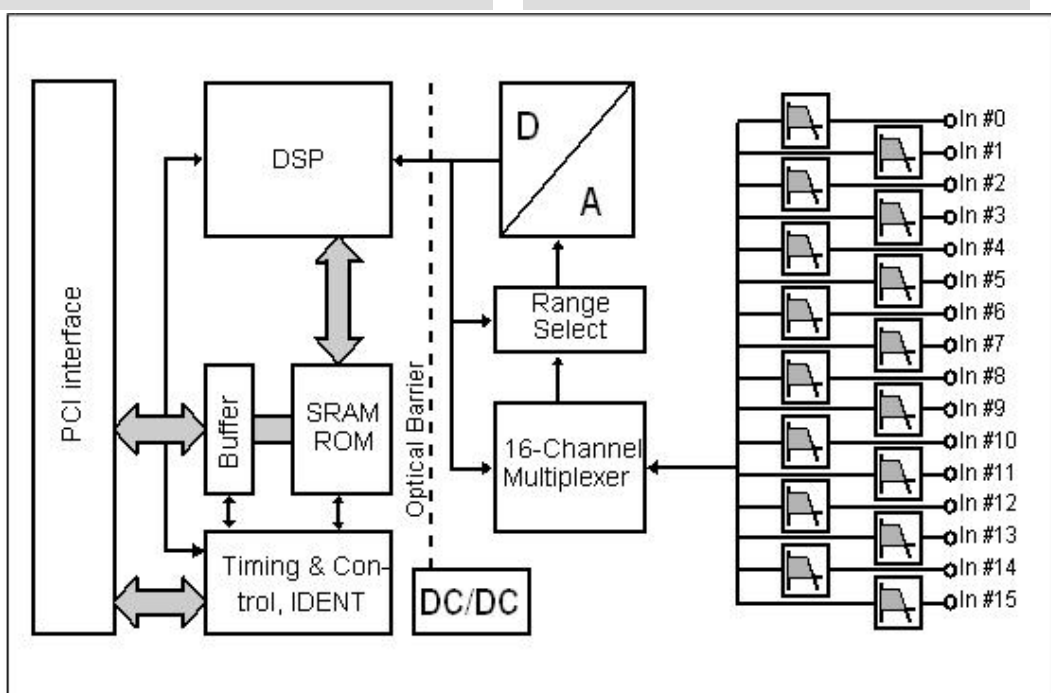

AcQ International BV
Alanenweg 6
5342 PV OSS
The Netherlands

Phone +31 (0)412 64 19 22
Internet www.acq.nl
E-mail info@acq.nl